



SUNRAIL™

UL 3741

PV Hazard Control Installation Addendum

RELEASE, SEPTEMBER 2025

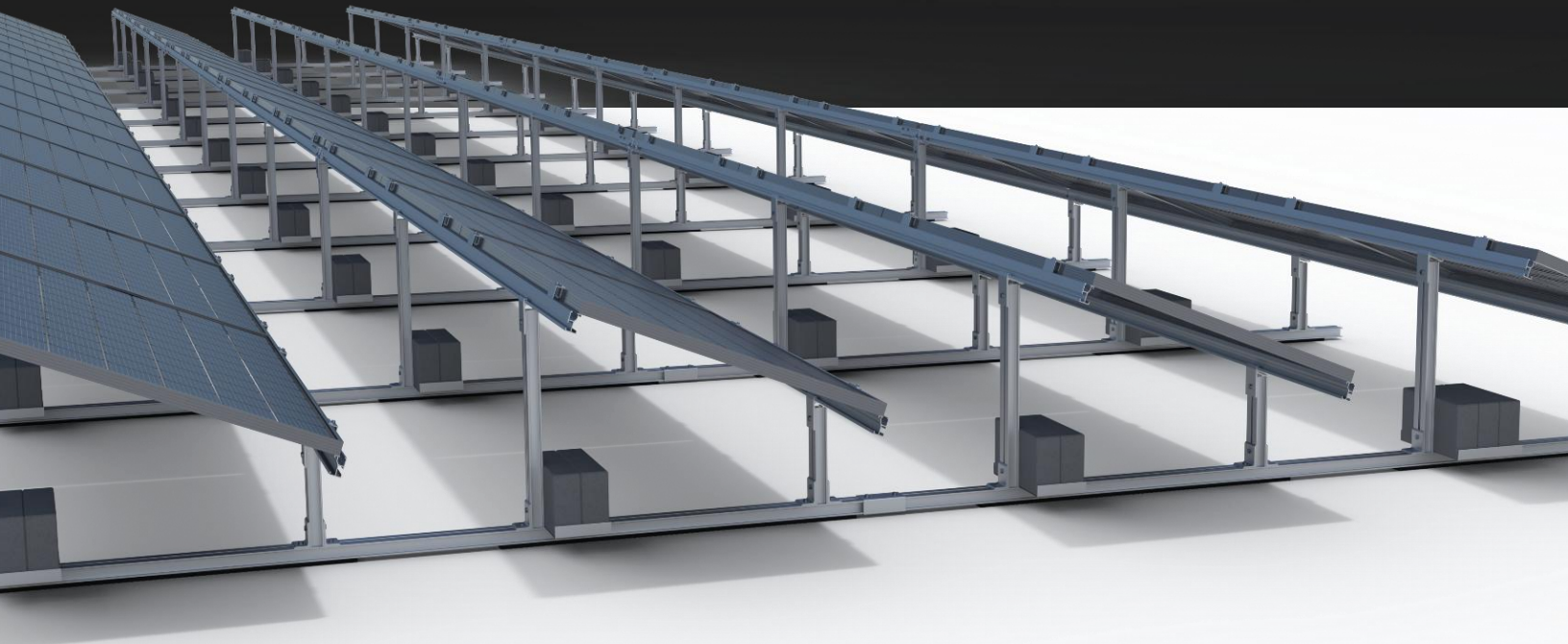

TABLE OF CONTENTS

TABLE OF CONTENTS.....	2
1. GENERAL.....	3
1.1 Introduction.....	3
1.2 Installer’s responsibility.....	3
2. CERTIFICATION & COMPLIANCE	4
2.1 ANSI/UL 3741 - 2020 NEC 690.12(B)(2)(1).....	4
2.2 UL 2703	4
2.3 Marking.....	4
2.3 Compatible Component Lists.....	6
3. CODE REQUIREMENTS	7
3.1 2020 NEC 690.12 – General Requirements.....	7
3.2 2020 NEC 690.12(B)(2) - Controlling Conductors within the array boundary.....	7
3.3 Array Design per UL 3741 and 2020 NEC 690.12	8
4. INSTALLATION	12
4.1 Wire Clips & Ties.....	12
4.2 Raceways	12
4.3 Detailed Examples – Landscape Orientation.....	13
4.4 Detailed Examples - Portrait Orientation	18
5. INVESTIGATED COMPONENTS.....	23

1. GENERAL

1.1 Introduction

This manual describes the proper procedure to install the flat roof system to meet the requirements of the UL3741 PV Hazard Control Standard. All installers must thoroughly read this manual and have a clear understanding of the installation procedures prior to installation. Failure to follow the methods and procedures outlined in this guide may result in injury and/or damage to property.

 **WARNING** Warning: to reduce the risk of injury, read all instructions.

1.2 Installer's responsibility

- Ensure safe installation of all electrical aspects of the array. All electrical installation and procedures should be conducted by a licensed and bonded electrician or solar contractor. Routine maintenance of a module or panel shall not involve breaking or disturbing the bonding path of the system. All work must comply with national, state and local installation procedures, product, and safety standards.
- Comply with all applicable local or national building and fire codes, including any that may supersede this manual.
- Ensure all products are appropriate for the specific installation and are designed for the installation environment.
- PV system must be installed on a non-conductive roof.
- Use only Opsun parts or parts recommended by Opsun; substituting parts may void any applicable warranties.
- Ensure provided information is accurate. Issues resulting from inaccurate information are the installer's responsibility.
- Ensure bare copper grounding wire does not contact aluminum and zinc-plated steel components, to prevent risk of galvanic corrosion.
- If loose components or loose fasteners are found during periodic inspection, re-tighten immediately. Any components showing signs of corrosion or damage that compromise safety shall be replaced immediately.
- Ensure the system is grounded and bonded to meet the requirements of the National Electric Code.
- Disconnect AC power before servicing or removing modules, AC modules, microinverters and power optimizers.
- Review module manufacturer's documentation for compatibility and compliance with warranty terms and condition.
- For each component inside and outside the array boundary, ensure that the installation, the operation and the maintenance follow all requirements underlined in the manufacturer's installation operation and maintenance manuals.

2. CERTIFICATION & COMPLIANCE

UL 2703 Listed
UL 3741 Listed



2.1 ANSI/UL 3741 - 2020 NEC 690.12(B)(2)(1)

UL 3741 Listed. Conforms to ANSI/UL 3741 - standard for safety - photovoltaic hazard control.

Prior to installation, refer to module and inverter datasheets to verify compliance with the following:

- PVHCS System Voltage: 1000V MAX
- String Max System Voltage: 600Vdc and 1000Vdc
- Max PV Module Surface Area: 3.11m² (33.44 ft²) for SunRail

Follow the instructions described in this document to ensure UL 3741 compliance.

2.2 UL 2703

UL 2703 Listed. Conforms to UL 2703 – standard for safety - Mounting Systems, Mounting Devices, Clamping/Retention Devices, and Ground Lugs for Use with Flat-Plate Photovoltaic Modules and Panels.

Refer to the main installation manual for UL 2703 compliance requirements

2.3 Marking

Each Array should be marked with a marking plate, placed as close as possible to the grounding lug.

2. CERTIFICATION & COMPLIANCE



**3318 Second St E.
Cornwall (ON), K6H 6J8, Canada**

+1-418-651-4040
info@opsun.com

Made in / fait au Canada

Conforms to / Conforme à : ANSI/UL STD 3741

Identification

SunRail

Project/Projet

<u>Fuse Rating :</u>	35A
<u>Fire Rating & Mechanical Load Testing :</u>	See installation manual, Voir manuel d'installation

Production Date (below / ci-bas) :

PRODUCTION DATE



**772 Gallimore Dairy Rd
High Point, NC, 27265, USA**

+1-418-651-4040
info@opsun.com

Made in / fait au USA

Conforms to / Conforme à : ANSI/UL STD 3741

Identification

SunRail

Project/Projet

<u>Fuse Rating :</u>	35A
<u>Fire Rating & Mechanical Load Testing :</u>	See installation manual, Voir manuel d'installation

Production Date (below / ci-bas) :

PRODUCTION DATE

2. CERTIFICATION & COMPLIANCE

2.3 Compatible Component Lists

Please note that not all of the following components are necessarily required for 2020 NEC 690.12 and ANSI/UL 3741 compliance. Refer to [section 3.3](#) for more details.

PV Hazard Control Equipment or Components evaluated at 1000V Max system voltage:

- **PV Modules:** Type 1, 2 and 29 modules listed in the SunRail Installation Manual under *VERIFIED COMPATIBLE PV MODULES*.
- **PV Inverters:** All specifically investigated Inverters of [section 5](#).
- **Opsun Components:** All Components listed in the SunRail Installation Manual under *CERTIFIED OPSUN PARTS*.
- **PV Wire & Distributed Generation (DG) Cables:** All UL 4703 listed cables.
- **PV Modules DC & AC Connectors:** All UL 6703 listed connectors.
- **Cables Ties:**
 - All UL 62275 listed cable ties, or
 - all specifically investigated cables ties of [section 5](#).
- **Cable Clips:**
 - All UL 1565 listed cable clips, or
 - All specifically investigated cable clips of [section 5](#).
- **Wireways:**
 - All UL 870 listed wireways, or
 - RayTray V2 Solar Management System.
- **Conduits (all sizes):**
 - **Electrical Metallic Conduit (EMC) & Fittings:**
 - All UL 797 listed EMC, or
 - All specifically investigated EMC of [section 5](#).
 - **Intermediate Metallic Conduit (IMC) & Fittings:**
 - All UL 1242 listed IMC, or
 - All specifically investigated IMC of [section 5](#).
 - **Rigid Metal Conduit (RMC) & Fittings:**
 - All UL 6 listed RMC, or
 - All specifically investigated RMC of [section 5](#).
 - **Rigid Aluminium Conduit (RAC) & Fittings:**
 - All UL 6A listed RAC, or
 - All specifically investigated RAC of [section 5](#).
 - **Flexible Non-metallic Conduit (FNC) & Fittings:**
 - All UL 1660 listed FNC,
 - All UL 514B listed fittings, or
 - All specifically investigated FNC of [section 5](#).
 - **PVC conduit & Fittings:**
 - All UL 651 listed conduits and fitting

3. CODE REQUIREMENTS

3.1 2020 NEC 690.12 – General Requirements

2020 NEC690.12 Rapid Shutdown of PV Systems on Buildings requires that all PV arrays installed on or in buildings shall include rapid shutdown functions to reduce shock hazard for Fire Fighters (FF) in accordance with 690.12(A) through (D):

(A) Controlled Conductors: PV System DC circuits & Inverter output circuits originating from inverters located within array boundary.

(B) Controlled Limits

(1) Outside Array Boundary: $\leq 30V$ within 30 seconds.

(2) Inside Array Boundary:

(1) Listed PV Hazard Control System (UL3741)

(2) $\leq 80V$ within 30 seconds after rapid shutdown initiation.

(3) PV array without exposed wiring methods or conductive parts

(C) Initiation devices: Initiation device(s) shall initiate the rapid shutdown function of the PV system.

(D) Equipment: Equipment that performs rapid shutdown functions other than initiation devices, such as listed disconnect switches, circuit breakers, or control switches.

*NEC Defines the arrays as a mechanically and electrically integrated grouping of modules with support structure, including any attached system components such as inverter(s) or DC-to-DC converter(s) and attached associated wiring. This indicates the Opsun racking and collocated inverter(s) are part of the arrays.

**NEC 690.12(B) defines the array boundary as 1ft from array in all directions. This indicates that the array boundary can extend 1ft from the edge of the Opsun racking, inverter or module.

3.2 2020 NEC 690.12(B)(2) - Controlling Conductors within the array boundary

The Opsun Photovoltaic Hazard Control System (PVHCS) is a UL 3741 Listed system that complies with NEC 690.12(B)(2)(1), when installed by qualified persons per the installation procedures outlined in the Opsun System Installation Manual and this Addendum. Please refer to the following pages of this addendum for various example cases of system designs that comply with 690.12(B)(2).

3. CODE REQUIREMENTS

3.3 Array Design per UL 3741 and 2020 NEC 690.12

Following case studies in Section 3.3.1 to 3.3.4 are not part of UL 3741 or verified by Intertek but are provided by Opsun to show examples of installation configuration that comply with NEC 690.12(B). Compliance is not limited to these examples:

3.3.1 CASE I: UL 3741 Listed System

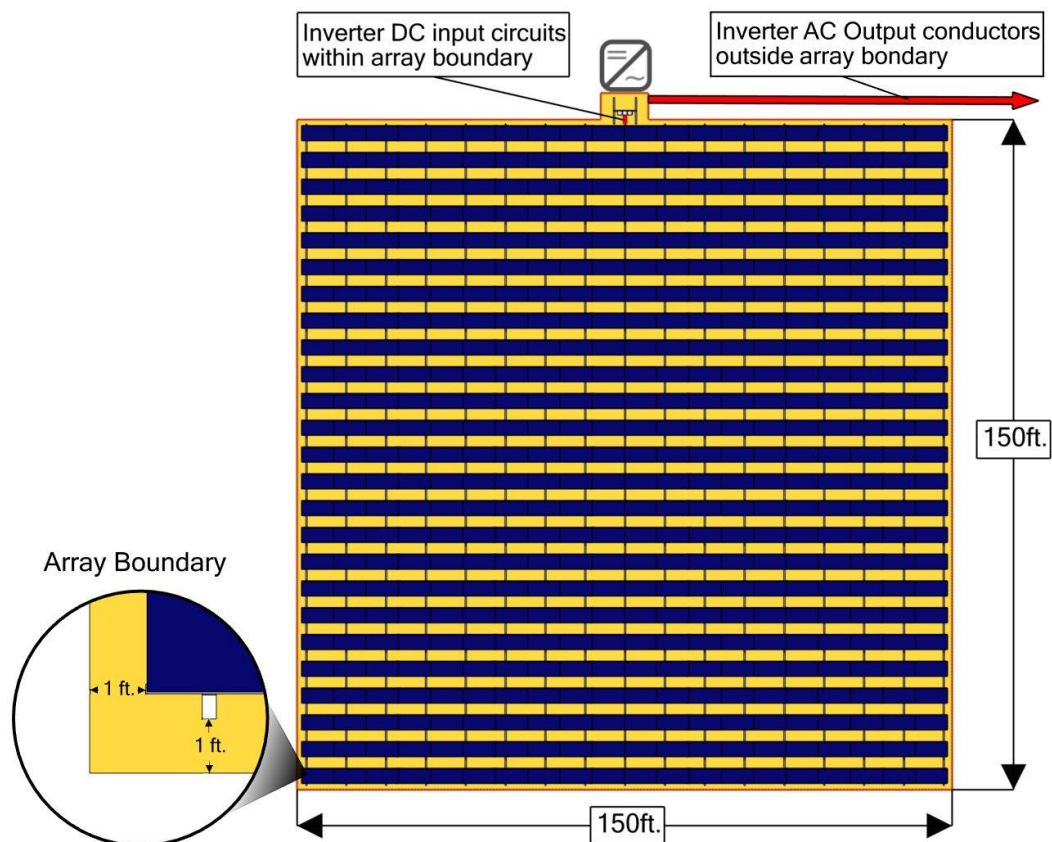

Array(s) complies with 690.12(B) by utilizing a listed UL 3741 PV Hazard Control System

- All inverter input circuits (DC) are contained within the PV array boundary and do not require additional measures to reduce string voltages per 690.12(B)(2)(1) after initiation (Inverter DC disconnect, AC breaker or AC disconnect).
- Inverter output circuits (AC) are outside of the array boundary and meet the 690.12(B)(1) requirement after initiation (AC breaker or AC disconnect).

PV Circuit Voltages:

- Outside Array Boundary: $\leq 30V$ within 30 sec
- Inside Array Boundary: $\leq 1000V$

3. CODE REQUIREMENTS

3.3.2 CASE II: UL 3741 Listed System with Contiguous Sub-Array

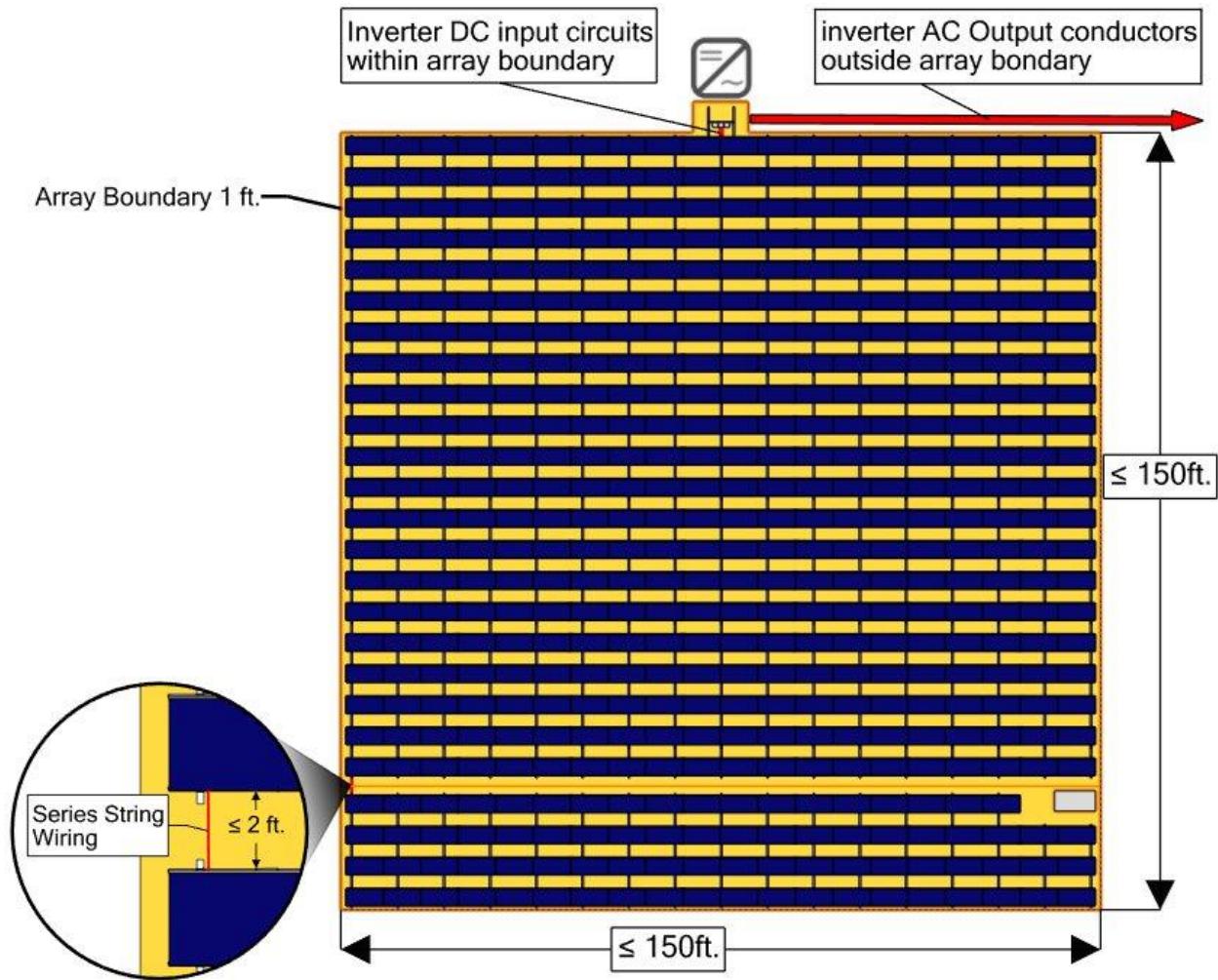

Maintaining NEC Compliance with conductors installed between multiple sub-arrays

- Maximum 2 ft. spacing between all array components resulting in a single array boundary.

PV Circuit Voltages:

- Outside Array Boundary: $\leq 30V$ within 30 sec
- Inside Array Boundary: $\leq 1000V$

3. CODE REQUIREMENTS

3.3.3 CASE III: UL 3741 Listed System with Non-Contiguous Sub-Array

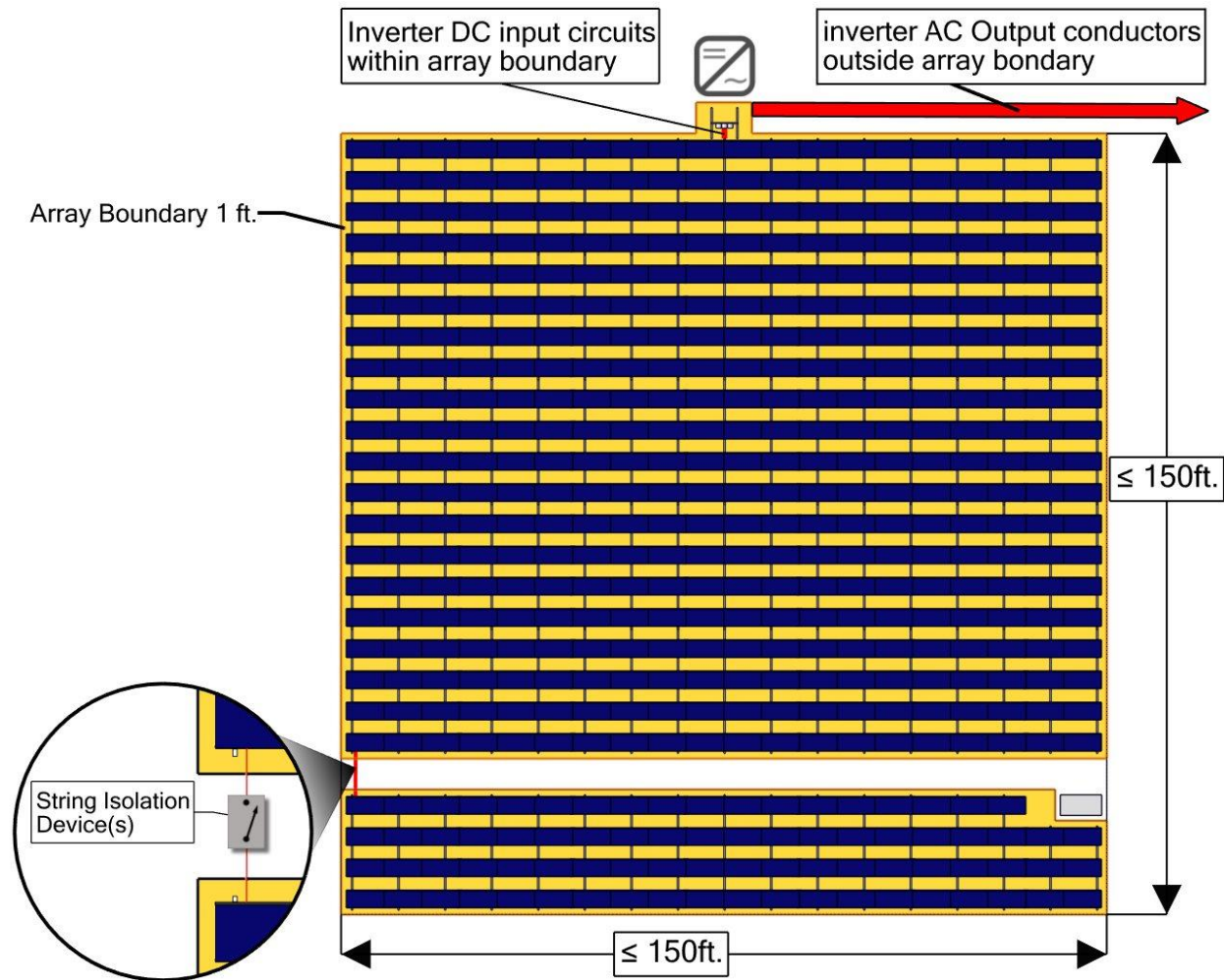

Maintaining NEC Compliance with conductors installed between multiple sub-arrays

- Complete string must be connected to a single isolation device.
- If used for a partial string, isolation devices required on both sides of the pathway since voltage will be present on both sides.

PV Circuit Voltages:

- Outside Array Boundary: ≤30V within 30 sec
- Inside Array Boundary: ≤1000V

3. CODE REQUIREMENTS

3.3.4 CASE IV: UL 3741 Listed System with MLPE Sub-Array

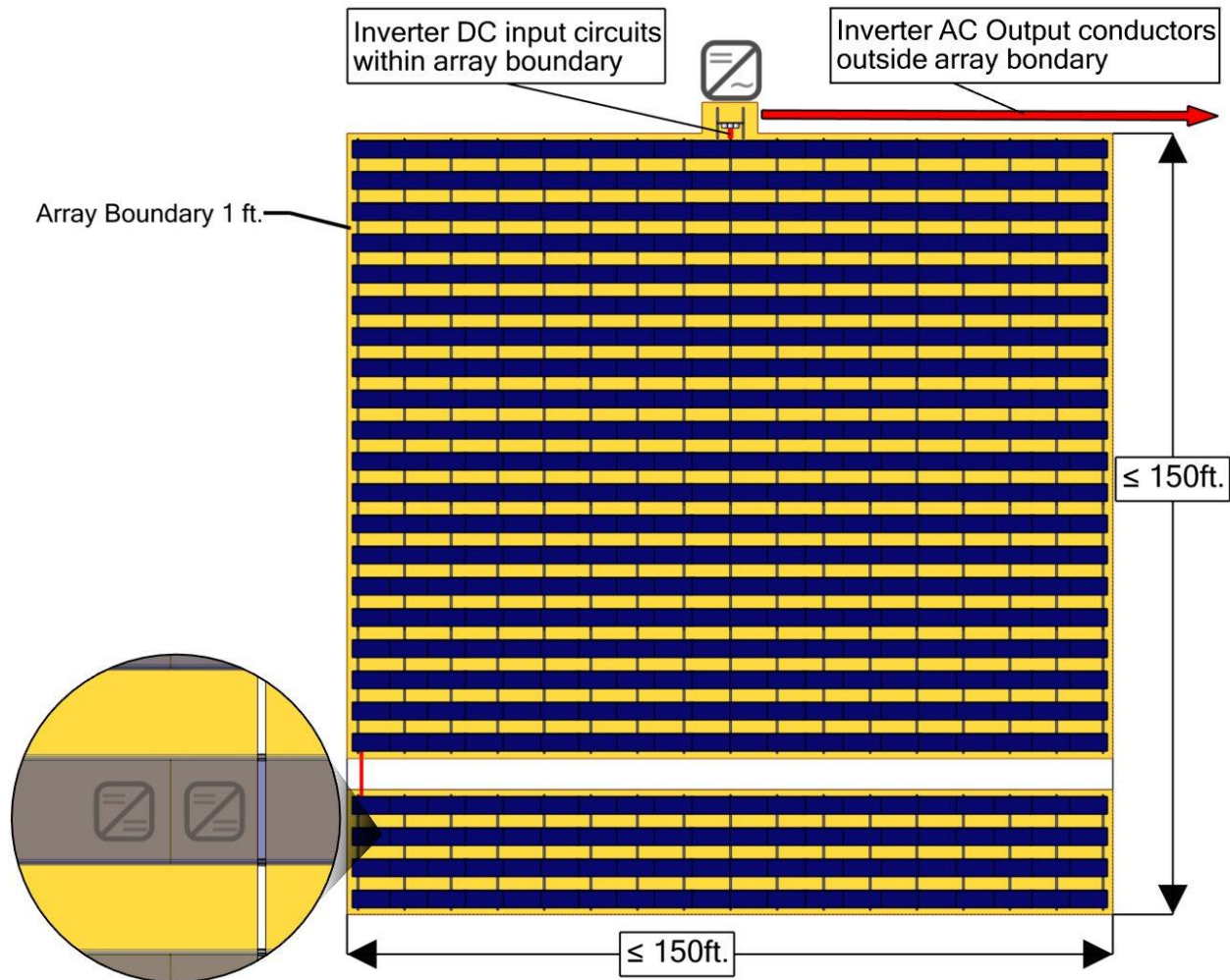

Maintaining NEC Compliance with sub-array(s) outside of array Boundary

- Utilize Module-Level Power Electronics on lower sub-array
- All modules on the same inverter input must be connected to an MLPE. Upper array utilizes UL 3741 listing without MLPEs for compliance.

PV Circuit Voltages:

- Outside Array Boundary: $\leq 30\text{V}$ within 30 sec
- Inside Array Boundary: $\leq 1000\text{V}$
- Sub-Array Boundary: $\leq 80\text{V}$ Inside within 30 Seconds

4. INSTALLATION

The Opsun Wire management components noted in the list of approved PVHCS equipment were evaluated and approved for providing wire protection against potential firefighter interactions. To achieve wire protection as required per UL 3741, all wires shall be routed such that they are not exposed to potential firefighter interactions. It can be achieved by following these steps:

4.1 Wire Clips & Ties

- Route wires under the modules using approved wire clips and ties.
- Do not allow wires to sag between clips.
- Do not overtighten or pinch wires.
- Utilize wire clips to prevent contact between the wire and metallic components of the module and racking system.

4.2 Raceways

- Protect wires in exposed areas such as inner row spaces and pathways by utilizing the listed raceways.
- Ensure that PV wire is not exposed to sharp edges when entering or exiting listed raceways.

4. INSTALLATION

4.3 Detailed Examples – Landscape Orientation



4.3.1 Wire clips to panels

Use only approved edge clips and cable ties. Secure the conductor(s) with a cable tie every 16 inches, tightening each tie so the wiring stays firmly in place. Position all clips along the edge of the PV module frame, beneath the system.

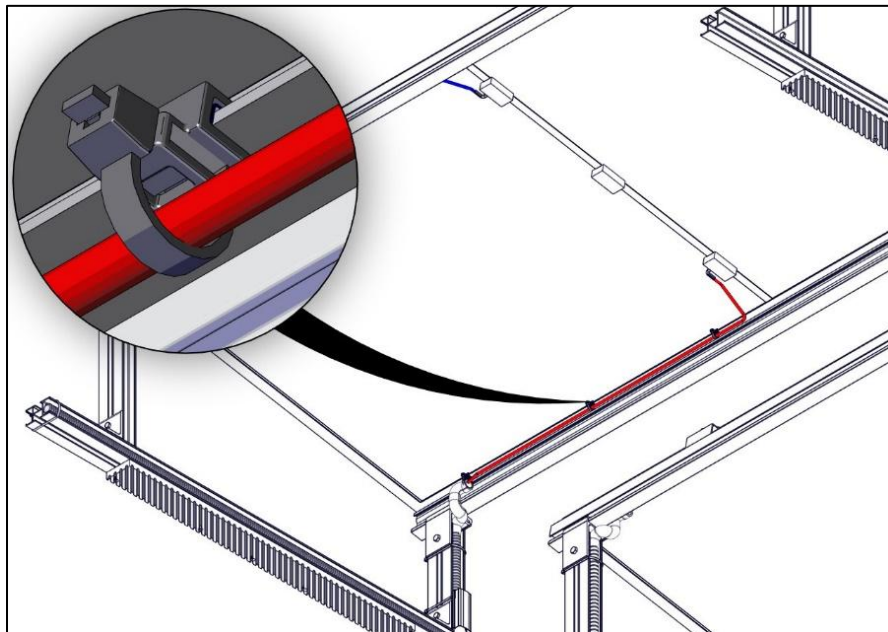

4. INSTALLATION

4.3.2 Raceways Between Rows

Use only approved conduits, cable ties, or Opsun wire clips. When installing flexible non-metallic conduit (FNC), route the conduit through the aluminum rails for protection and fasten it with cable ties.

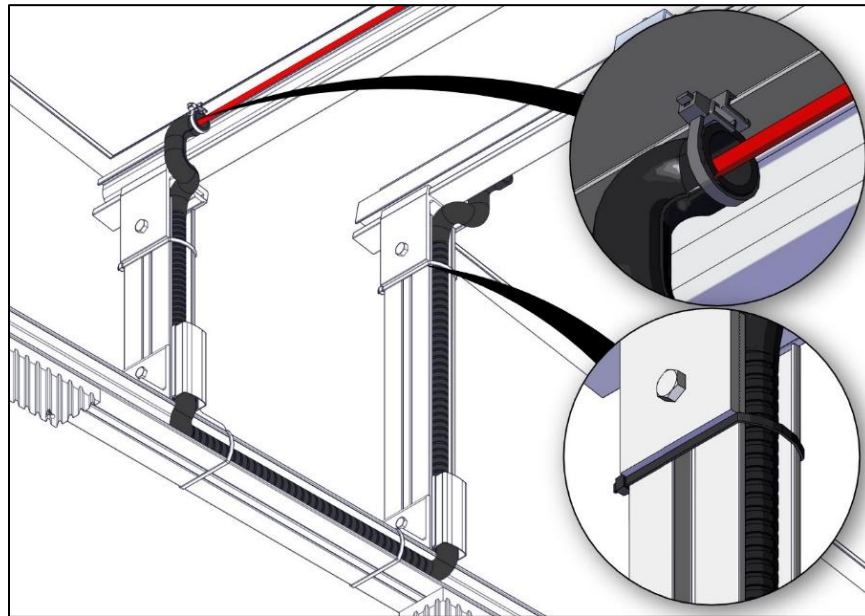

4.3.3 Home Raceways

Use approved conduits, cable ties or Opsun wire clip. When using flexible non-metallic conduit (FNC), run the FNC through the aluminium rails and secure with cable ties.

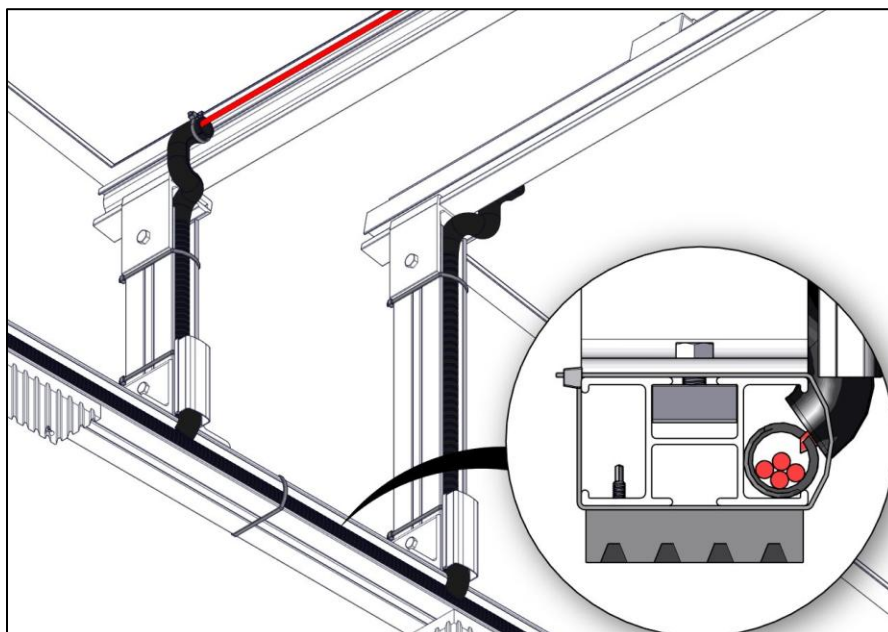

4. INSTALLATION

4.3.4 Protection Against Firefighter Falling with Tool – Leg Junction

When installing flexible non-metallic conduit (FNC), use Opsun clips and protective guards to shield the lower junction area from potential impact by falling firefighter tools.

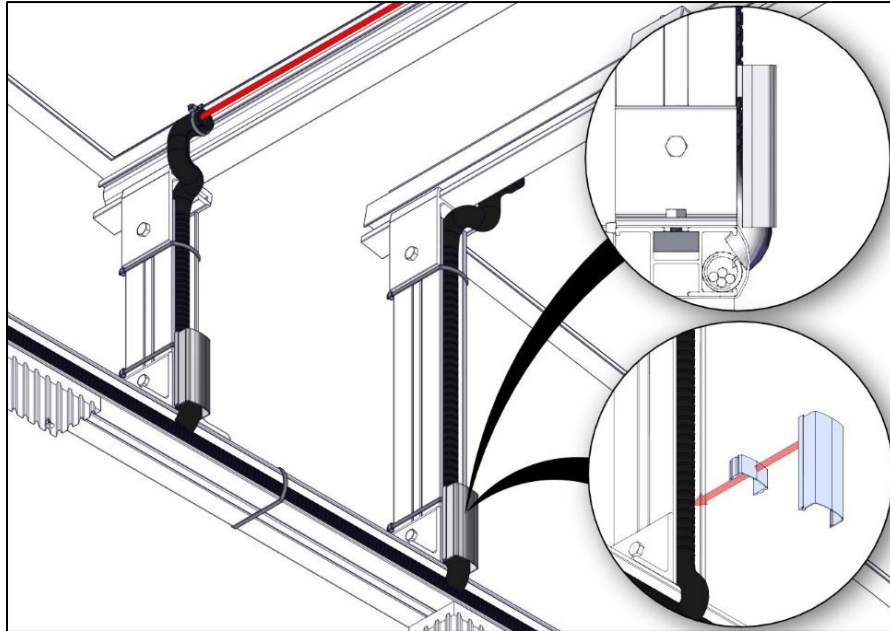

4. INSTALLATION

4.3.5 Protection Against Firefighter Falling with Tool – Rail Linker

When installing flexible non-metallic conduit (FNC), route the conduit through the linker or create a protective loop. Use Opsun clips and guards to shield this section from falling firefighter tools.

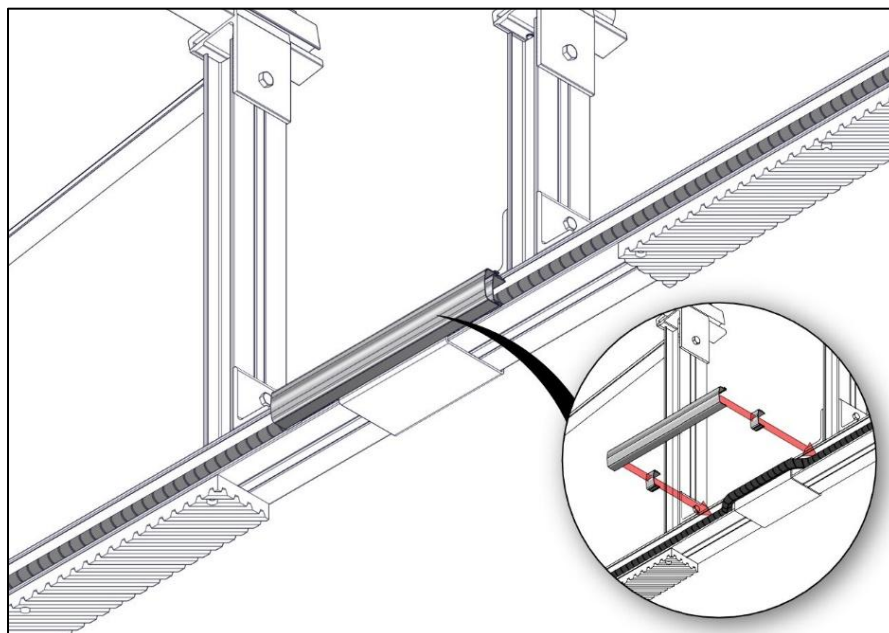
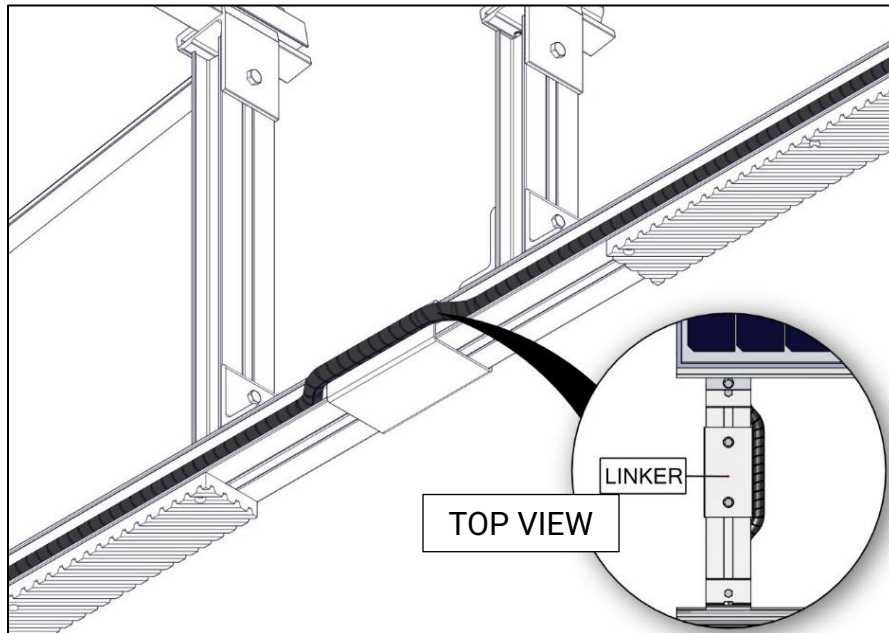

4. INSTALLATION

4.3.6 Securing Flexible Non-Metallic Conduit with Aluminium Clips

Flexible non-metallic conduit (FNC) can be fastened inside the rail using aluminum clips rather than plastic cable ties.

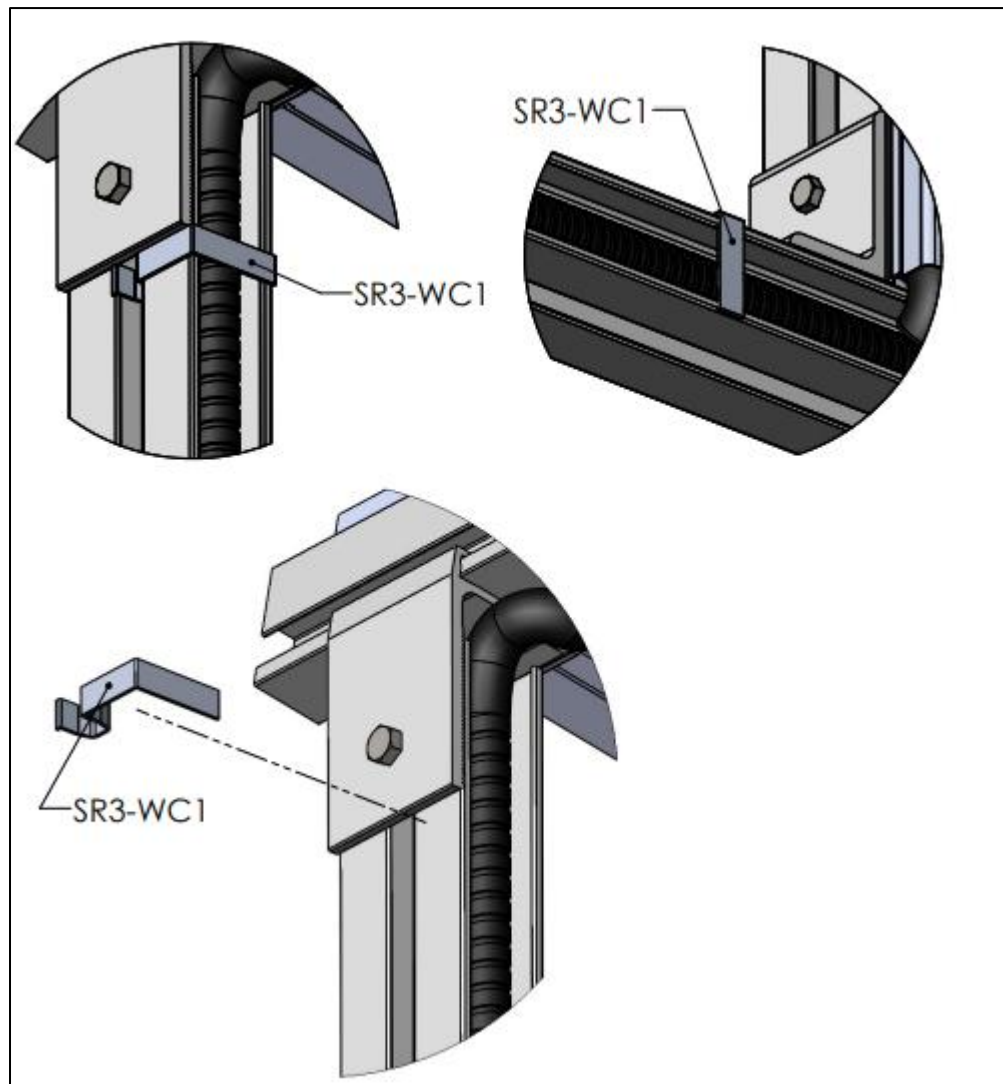

4. INSTALLATION

4.4 Detailed Examples - Portrait Orientation



4.4.1 Wire clips to panels

Use approved edge clips and cable ties. Secure the conductor(s) with a cable tie every 16 inches, tightening each tie so the wiring stays firmly in place. Position all clips along the edge of the PV module frame, beneath the system.

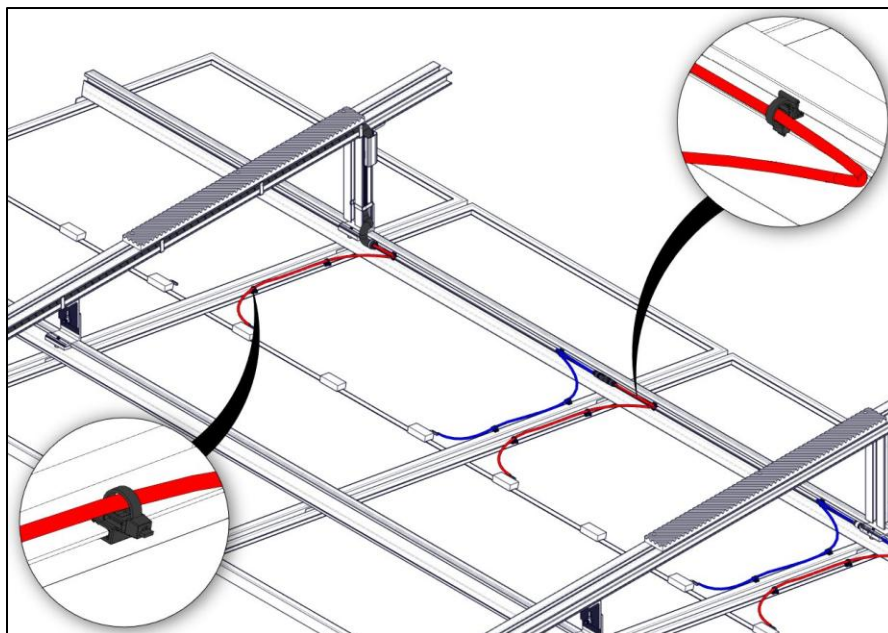

4. INSTALLATION

4.4.2 Raceways Between Rows

Use only approved conduits, cable ties, or Opsun wire clips. When installing flexible non-metallic conduit (FNC), route the conduit through the aluminum rails for protection and fasten it with cable ties.

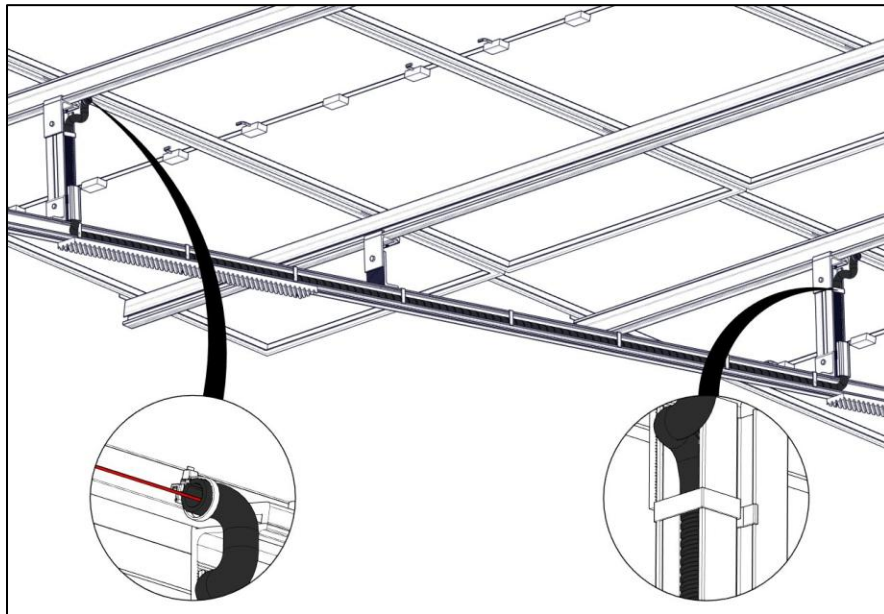

4.4.3 Home Raceways

Use approved conduits, cable ties or Opsun wire clip. When using flexible non-metallic conduit (FNC), run the FNC through the aluminium rails and secure with cable ties.

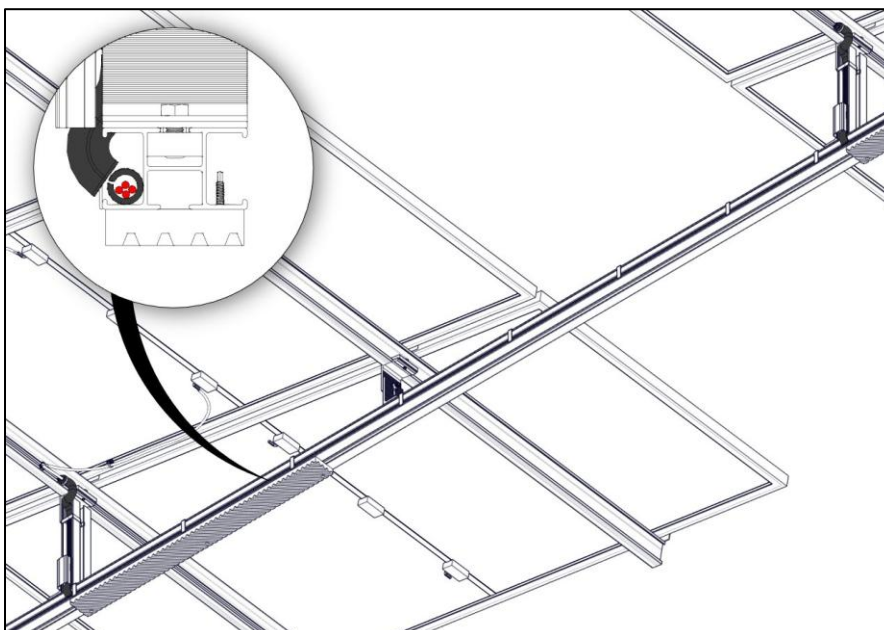

4. INSTALLATION

4.4.4 Protection Against Firefighter Falling with Tool – Leg Junction

When installing flexible non-metallic conduit (FNC), use Opsun clips and protective guards to shield the lower junction area from potential impact by falling firefighter tools.

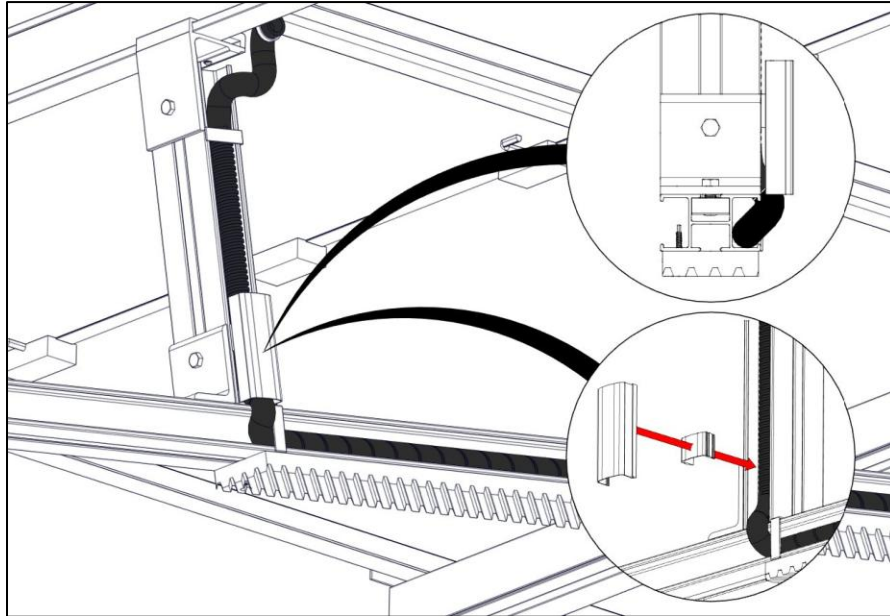

4. INSTALLATION

4.4.5 Protection Against Firefighter Falling with Tool – Rail Linker

When installing flexible non-metallic conduit (FNC), route the conduit through the linker or create a protective loop. Use Opsun clips and guards to shield this section from falling firefighter tools.

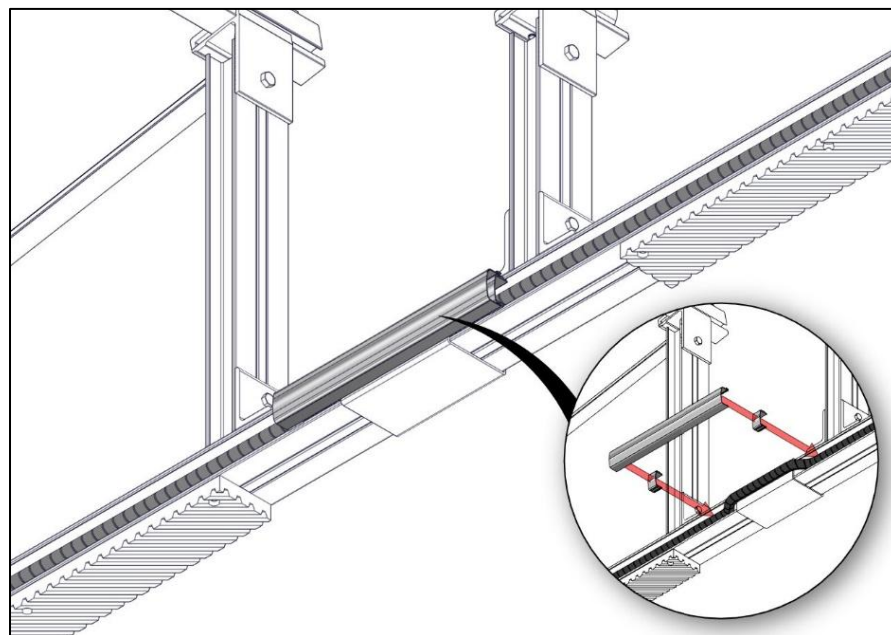
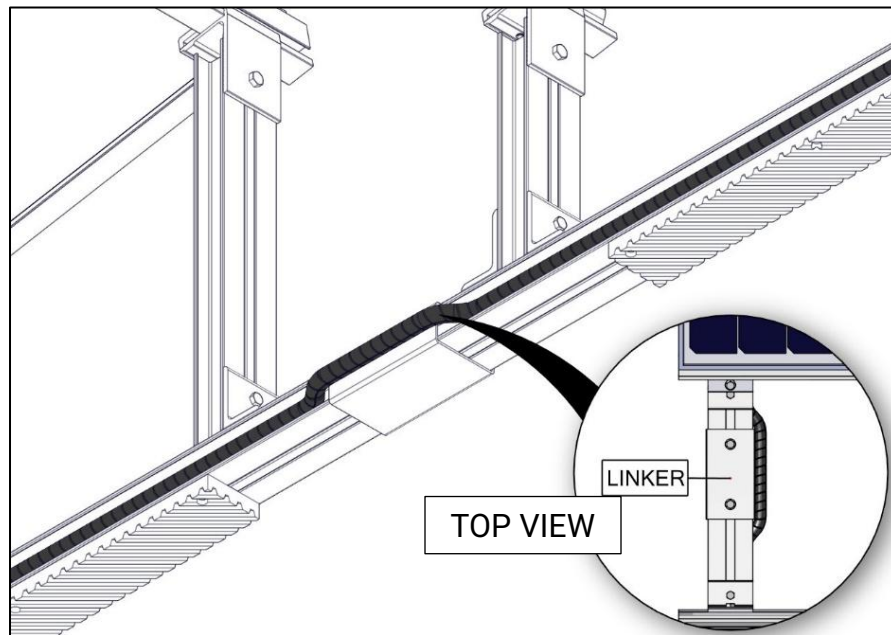

4. INSTALLATION

4.4.6 Securing Flexible Non-Metallic Conduit with Aluminium Clips

Flexible non-metallic conduit (FNC) can be fastened inside the rail using aluminum clips rather than plastic cable ties.

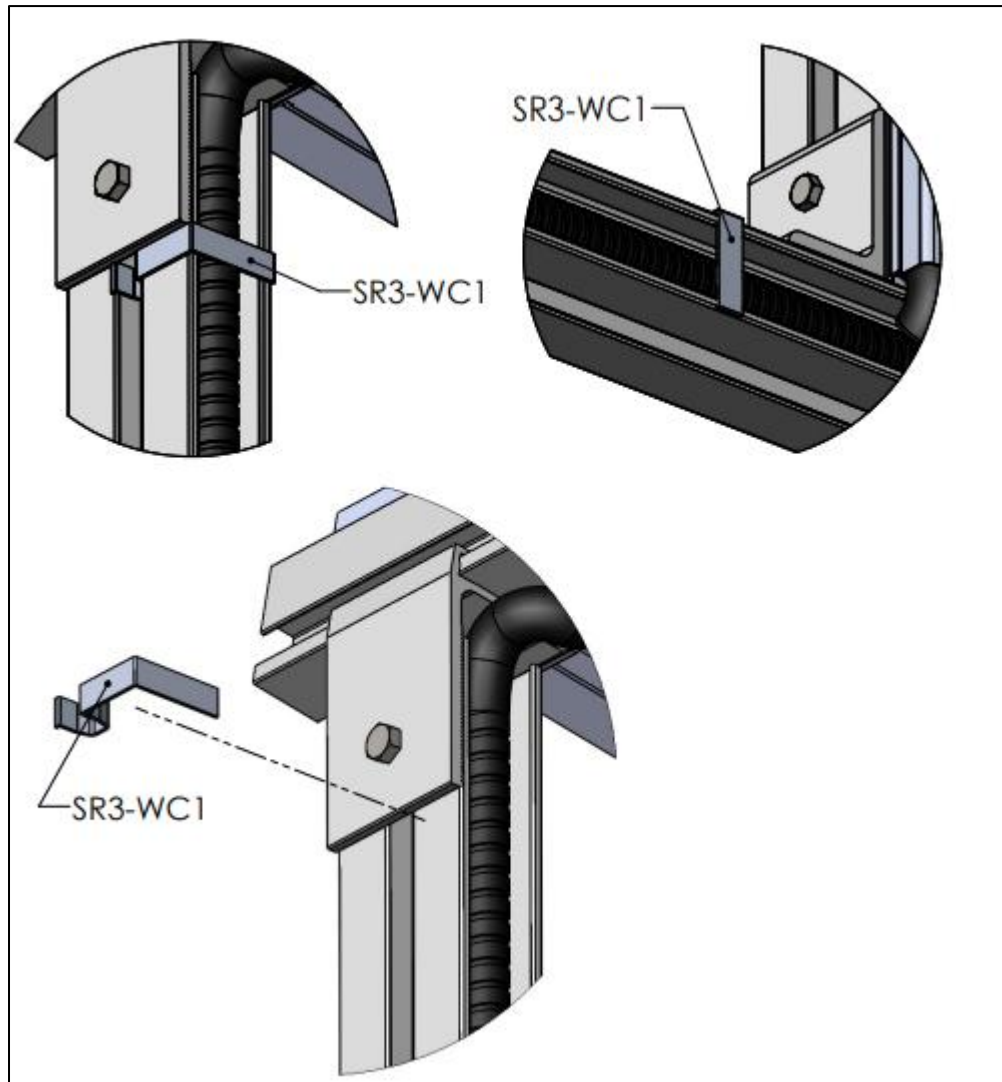

5. INVESTIGATED COMPONENTS

The following lists contain equipment specifically investigated for UL 3741. In some cases, equivalent equipment is allowable. See [section 2.3](#).

Components	Manufacturer/ trademark	Type / model
PV Racking System	Opsun Systems	SunRail
PV modules	Various	Various
Inverter	Canadian Solar (3186984)	CSI-25K-T480GL01-UB
		CSI-25KTL-GS-FLB
		CSI-30K-T480GL01-UB
		CSI-30KTL-GS-FLB
		CSI-36K-T480GL01-UB
		CSI-36KTL-GS-FLB
		CSI-40K-T480GL01-UB
		CSI-40KTL-GS-FLB
		CSI-50K-T480GL01-UB
		CSI-50KTL-GS-B
		CSI-60K-T480GL01-UB
		CSI-60KTL-GS-B
		CSI-66K-T480GL01-UB
		CSI-66KTL-GS-B
Inverter	Canadian Solar (80059142)	CSI-100K-T480GL02-U
		CSI-100K-T480GL03-U
		CSI-75K-T480GL02-U
		CSI-75K-T480GL03-U
		CSI-80K-T480GL02-U
		CSI-80K-T480GL03-U
		CSI-90K-T480GL02-U
		CSI-90K-T480GL03-U
Inverter	Chint Power (5020351) (70128088)	CPS SCA25KTL-DO/US-208
		CPS SCA25KTL-DO-R/US-480
		CPS SCA36KTL-DO/US-480
		CPS SCA50KTL-DO/US-480
		CPS SCA60KTL-DO/US-480
Inverter	Delta Electronics Americas (70113203)	M4-TL-US
		M5-TL-US
		M6-TL-US
		M8-TL-US
Inverter	FIMER S.p.A. (CU 7222527301)	PVS-60-TL-R-US
		PVS-60-TL-SC-R-US
		PVS-60-TL-S-R-US
		UNO-DM-3.3-TL-PLUS-US-Q
		UNO-DM-3.8-TL-PLUS-US-Q
		UNO-DM-4.6-TL-PLUS-US-Q
		UNO-DM-5.0-TL-PLUS-US-Q
		UNO-DM-6.0-TL-PLUS-US-Q
Inverter	Fronius (2760387)	Fronius Symo 10.0-3 208-240
		Fronius Symo 10.0-3 208-240 Lite
		Fronius Symo 10.0-3 480
		Fronius Symo 10.0-3 480 Lite

5. INVESTIGATED COMPONENTS

Components	Manufacturer/ trademark	Type / model
		Fronius Symo 12.0-3 208-240
		Fronius Symo 12.0-3 208-240 Lite
		Fronius Symo 12.5-3 480
		Fronius Symo 12.5-3 480 Lite
		Fronius Symo 15.0-3 208
		Fronius Symo 15.0-3 208 Lite
		Fronius Symo 15.0-3 480
		Fronius Symo 15.0-3 480 Lite
		Fronius Symo 17.5-3 480
		Fronius Symo 17.5-3 480 Lite
		Fronius Symo 20.0-3 480
		Fronius Symo 20.0-3 480 Lite
		Fronius Symo 22.7-3 480
		Fronius Symo 22.7-3 480 Lite
		Fronius Symo 24.0-3 480
		Fronius Symo 24.0-3 480 Lite
Inverter	Fronius (2779302)	Fronius Primo 3.8-1 208-240
		Fronius Primo 3.8-1 208-240 Lite
		Fronius Primo 5.0-1 208-240
		Fronius Primo 5.0-1 208-240 Lite
		Fronius Primo 6.0-1 208-240
		Fronius Primo 6.0-1 208-240 Lite
		Fronius Primo 7.6-1 208-240
		Fronius Primo 7.6-1 208-240 Lite
		Fronius Primo 8.2-1 208-240
		Fronius Primo 8.2-1 208-240 Lite
Inverter	Fronius (70043714)	Fronius Primo 10.0-1 208-240
		Fronius Primo 10.0-1 208-240 Lite
		Fronius Primo 11.4-1 208-240
		Fronius Primo 11.4-1 208-240 Lite
		Fronius Primo 15.0-1 208-240
		Fronius Primo 15.0-1 208-240 Lite
		Primo 12.5-1 208-240
		Primo 12.5-1 208-240 Lite
Inverter	Fronius (70189546)	Fronius Symo Advanced 10.0-3 208-240
		Fronius Symo Advanced 10.0-3 208-240 Lite
		Fronius Symo Advanced 12.0-3 208-240
		Fronius Symo Advanced 12.0-3 208-240 Lite
		Fronius Symo Advanced 15.0-3 480
		Fronius Symo Advanced 15.0-3 480 Lite
		Fronius Symo Advanced 20.0-3 480
		Fronius Symo Advanced 20.0-3 480 Lite
		Fronius Symo Advanced 22.7-3 480
		Fronius Symo Advanced 22.7-3 480 Lite
		Fronius Symo Advanced 24.0-3 480
		Fronius Symo Advanced 24.0-3 480 Lite
Inverter	Fronius (80203040)	Primo Gen24 10.0 208-240
		Primo Gen24 10.0 208-240 Plus
		Primo Gen24 3.8 208-240

5. INVESTIGATED COMPONENTS

Components	Manufacturer/ trademark	Type / model
		Primo Gen24 3.8 208-240 Plus
		Primo Gen24 5.0 208-240
		Primo Gen24 5.0 208-240 Plus
		Primo Gen24 6.0 208-240
		Primo Gen24 6.0 208-240 Plus
		Primo Gen24 7.7 208-240
		Primo Gen24 7.7 208-240 Plus
Inverter	GE (SGSNA/22/GZ/00174)	GEP11.4-1-MS-US30
		GEP5.0-1-MS-US30
		GEP6.0-1-MS-US30
		GEP7.7-1-MS-US30
		GEP9.6-1-MS-US30
Inverter	GoodWe (80023770)	GW5000A-MS
		GW6000A-MS
		GW7000A-MS
		GW7600A-MS
		GW8600A-MS
		GW9600A-MS
Inverter	GoodWe (80127114)	GW22-KLV-SMT-US
		GW28-KLV-SMT-US
Inverter	GoodWe (GZ-CERT220802012)	GW11K4-MS-US30
		GW5000-MS-US30
		GW50K-SMT-US
		GW6000-MS-US30
		GW60K-SMT-US
		GW7700-MS-US30
		GW9600-MS-US30
Inverter	Growatt (4003184)	MIN 10000TL-XH-US
		MIN 11400TL-XH-US
		MIN 3000TL-XH-US
		MIN 3800TL-XH-US
		MIN 5000TL-XH-US
		MIN 6000TL-XH-US
		MIN 7600TL-XH-US
		MIN 8200TL-XH-US
		MIN 9000TL-XH-US
Inverter	SMA Solar Technology AG (E210376)	Core 1 STP 33-US-41
		Core 1 STP 50-US-41
		Core 1 STP 62-US-41
		STP 20-US-50
		STP 25-US-50
		STP 30-US-50
Inverter	SolarEdge (4004590)	SE100KUS
		SE10KUS
		SE110KUS
		SE120KUS
		SE17.3KUS
		SE30KUS
		SE40KUS

5. INVESTIGATED COMPONENTS

Components	Manufacturer/ trademark	Type / model
		SE50KUS
		SE80KUS
Inverter	Solectria Renewables, LLC (4004522)	PVI 25TL-480-R
Inverter	Solectria Renewables, LLC (70150964)	PVI 23TL-480
		PVI 28TL-480
Inverter	Solectria Renewables, LLC (70219787)	PVI 50TL-480
		PVI 60TL-480
Inverter	Solectria Renewables, LLC (80149912)	PVI 25TL-208
		PVI 36TL-480-V2
Inverter	Solis (Ginlong Technologies Co.,Ltd) (3186984)	Solis-25K-US
		Solis-30K-US
		Solis-36K-US
		Solis-40K-US
Inverter	Solis (Ginlong Technologies Co.,Ltd) (80016843)	Solis-1P10K-4G-US
		Solis-1P3.6K-4G-US
		Solis-1P5K-4G-US
		Solis-1P6K-4G-US
		Solis-1P7.5K-4G-US
		Solis-1P7.6K-4G-US
Inverter	Solis (Ginlong Technologies Co.,Ltd) (80032256)	S5-GC125K-US
		S5-GC60K-LV-US
Inverter	Solis (Ginlong Technologies Co.,Ltd) (80062600)	S5-GC60K-US
		S6-GC25K-US
		S6-GC30K-LV-US
		S6-GC33K-US
		S6-GC36K-US
		S6-GC40K-US
		S6-GC50K-US
		S6-GC60K-US
Inverter	Solis (Ginlong Technologies Co.,Ltd) (800722424)	S5-GC100K-US
		S5-GC75K-US
		S5-GC80K-US
		S5-GC90K-US
		Solis-100K-5G-US
		Solis-50K-US-F-LSW
		Solis-50K-US-F-SW
		Solis-60K-US-F-LSW
		Solis-60K-US-F-SW
		Solis-66K-US-F-LSW
		Solis-66K-US-F-SW
		Solis-75K-5G-US
		Solis-80K-5G-US
		Solis-90K-5G-US
Inverter	Sungrow Power Supply Co.,LTD. (80056224)	SG36CX-US
		SG60CX-US
Wiring Management Devices	RayTray (4009754)	RayTray V2
Wiring Management	Hellermann Tyton	LOC series
		RCB series

5. INVESTIGATED COMPONENTS

Components	Manufacturer/ trademark	Type / model
		RCC series
		RCD series
		T120R
		T150M
		T250M
		T255 series
		T30R
		T50 series
Conduit (not shown)	Various	Electrical Metallic Tubing (EMT)
		Rigid Metal Conduit (RMC)
		Intermediate Metal Conduit (IMC)
		Rigid Aluminium Conduit (RAC)

Inverters are Rapid Shutdown Certified and shall be mounted within the boundary values given in NEC.